

## API 6A TYPE 6B 15000 PSI BLIND & WELDING NECK FLANGES

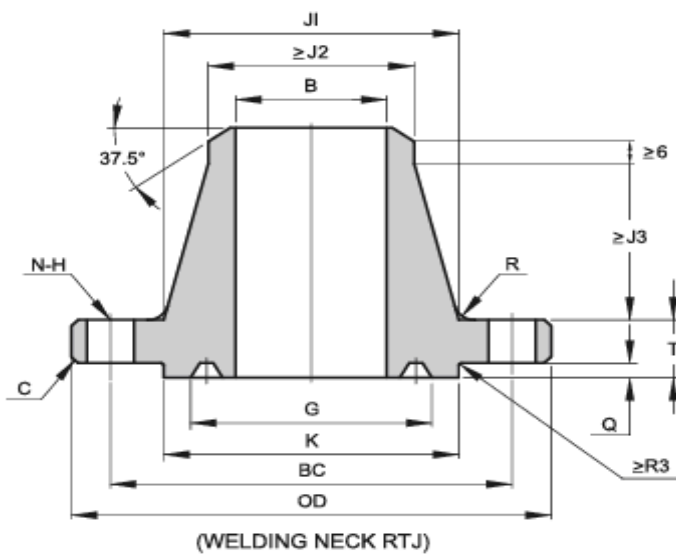
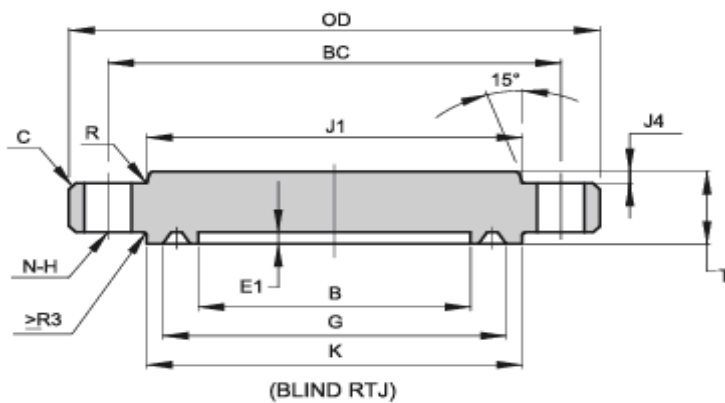

Size	B	OD	C	E1	Q	G	K	T	J1	J2	J3	J4	R	BC	N	H	BX
1 13/16"	46.8	210	3	-	5.56	77.77	106	45.3	97.6	71.4	47.6	-	10	160.3	8	26	151
2 1/16"	53.2	220	3	-	5.95	86.23	114	50.8	111.1	82.5	54	-	10	174.6	8	26	152
2 9/16"	65.9	255	3	-	6.75	102.77	133	57.2	128.6	100	57.1	-	10	200	8	29	153
3 1/16"	78.6	290	3	-	7.54	119	154	64.3	154	122.2	63.5	-	10	230.2	8	32	154
4 1/16"	104	360	3	-	8.33	150.62	194	78.6	195.3	158.7	73	-	10	290.5	8	39	155
5 1/8"	131	420	3	9.5	9.53	176.66	225	98.5	244.5	200	81.8	6.4	16	342.9	12	42	169
7 1/16"	180.2	505	6	11.1	11.11	241.83	305	119.1	325.4	276.2	92.1	7.9	16	428.6	16	42	156
9 "	229.4	650	6	12.7	12.7	299.06	381	146.1	431.8	349.2	123.8	14.2	16	552.4	16	51	157
11"	280.2	815	6	14.3	14.29	357.23	454	187.4	584.2	427	235.7	12.7	16	711.2	20	54	158
13 5/8"	346.9	885	6	15.9	15.88	432.64	541	204.8	595.3	528.6	114.3	17.5	25	771.5	20	61	159
18 3/4"	477	1160	6	18.3	18.26	577.9	722	255.6	812.8	730.2	155.6	35.1	25	1016	20	80	164

**Note:**

1. RING NUMBER BX,
2. C should be the max value
3. Tolerance and Ring Gasket according to API 6A-20TH